

Improvements on Semi Critical Assisted-Solvent Extraction of Biocrude Oil from *Spirogyra. sp* Macro Algae

^{1,3}Tulio Chavez-Gil, ²Hany F. Sobhi and ³Alexis Pacheco-Laracuente

¹Inorganic/Organometallic Division, Department of Natural Sciences, Coppin State University, 2100 West North Ave, Baltimore, MD 21216 - U.S.A

²Coppin Center for Organic Synthesis, Department of Natural Sciences, Coppin State University, 2100 West North Ave, Baltimore, MD 21216 - U.S.A

³Department of Biology, Chemistry and Environmental Sciences, Inter-American University of Puerto Rico, San German, PR 00683 - U.S.A

Article history

Received: 05-02-2018

Revised: 28-03-2018

Accepted: 17-04-2018

Corresponding Author:

Tulio Chavez-Gil
Inorganic/Organometallic
Division, Department of
Natural Sciences, Coppin State
University, 2100 West North
Ave, Baltimore, MD 21216 -
U.S.A
Email: tchavez-gil@coppin.edu

Abstract: Here, we report on an improved chemical method to extract hydrocarbons (**CH**) and Fatty Acid Methyl Esters (**FAME**) from wild green macro algae, which is higher than that carried out with conventional Soxhlet (**Sx**) and similar to that of Subcritical (**SbC**) or supercritical fluid (**SCE**) extraction methods. Crude oil plus residual biomass gave combined calorific values of 49.05 MJ/kg in agreement with its high-detected hydrocarbons (C, 72.56%; H, 10.59%) as desired for high quality liquid fuels. Oil extraction from macro algae was improved from 13.2% (**Sx**) to 34.8 % under Semi Critical Assisted-Solvent (**SmCA-Sol**) conditions. The extraction improvements are associated with an upgraded glassware design that works than in continuous or step-by-step operation under mild or high temperatures (<40, >500°C) as well as under moderate vacuum to above 1.0 atmosphere of pressure. The SmCA-Sol method creates a dynamic steam/solvent phase which exposes algae cell matrices to percolation in two opposite pathways leading to high yields of biomass extraction whether compared with traditional methods. Factors governing cell wall activation under SmCA-Sol conditions are discussed and compared with those carried out using advanced technologies and make recommendations towards future research regardless of macro algae chemical extraction of hydrocarbon and lipids.

Keywords: Azeotrope, Biomass, Calorific Value, Crude Oil, Percolation, Semi Critical Assisted-Solvent Extraction, Soxhlet Extraction, Supercritical Extraction, *Spirogyra. sp* Macro Algae

Introduction

The increased needs for diversification in electricity production and clean internal engine combustion by using green fuels have been experiencing technological, economic and environmental challenges to be implemented at all. The extraction of naturally available biofuels from biomass sources such as microorganisms has been proposed to overcome the energy needs as renewable resources for clean, safe and cost effective liquid fuels production (Sotoft *et al.*, 2010; Turkenburg, 2000; Sheehan *et al.*, 1998). Microbes like algae (macro and micro) are spectacular oxygen photosynthesis organisms that have been promoted as renewable ecosystems for biofuel

production at large scale, with potential to replace carbon fossil fuels (Cotton *et al.*, 2015).

Algae in particular, are primary producers in ecological systems due to they are widely distributed in either salted or fresh water around the world and are closely related with human ecosystem activities (Lee *et al.*, 2010; Kapdan and Kargi, 2006). Thus, biofuel produced by those photosynthesis species are often considered the fuels of the future due to their season-round cultivation, low-competition for land used whether compared with food crops, its higher calorific energy content, acting as environmental remediation ecosystems and similar to crops it's potential to produce fuels directly under genetically engineering improvements (Brennan and Owende, 2010). Initially,

biofuel was obtained from recycled waste cooking oils (i.e., palm, soybean, canola, rice bran, sunflower, coconut, corn oil, fish oil, chicken fat) but in recent times, the demand for algae biomass specially has gain great attention due to its broad industrial applications and its less hazardous byproducts (Hossain *et al.*, 2008). In particular, strains with filamentous cells such as *spirulina* and *spirogyra* are considered the most promising species for bioethanol production due to their high percentage of carbohydrates in their make-up and because they are of easy cultivation either in fresh or wastewater environments (Aitken and Antizar-Ladislao, 2012).

Wild green algae for example, growth up close to urban and industrial environments allowing these photosynthesis organisms consuming most of CO₂ produced by human activities and industrial emissions to release large amounts of oxygen by keeping human areas environmentally and economically sustainable (Ramachandra *et al.*, 2013).

However, the access for algae biofuel material using conventional technology and chemical procedures has been costly challenges than that encountered for oilseeds due to the difficulties presented by these microorganisms for its cell wall accessibility (Elliott *et al.*, 2013; Lee *et al.*, 2010; Hennenberg *et al.*, 2009). Thus, algae biofuel extraction have been dominated for a few number of processes that included but are not restricted to: (i) Solvent-assisted Soxhlet (Ghasemi *et al.*, 2014), (ii) Ultra-sonication (Metherel *et al.*, 2009), (iii) Microwave-assisted extraction (mechanical) (Šoštarič *et al.*, 2012), (iv) Sub-critical (Sahena *et al.*, 2009), (v) Super-critical fluid (Soh and Zimmerman, 2011) and (vi) direct Thermochemical conversion of microalgae biomass into bio-fuel (Huang *et al.*, 2011; Schafer *et al.*, 1998).

In last twenty years, subcritical co-solvents (Cheng *et al.*, 2012) and supercritical carbon dioxide (SC-CO₂) (Halim *et al.*, 2011) are the most referenced processes for biomass extraction highlighting their advantages over traditional methods (distillation, press, sonication) due to the possibility of use a liquid or gas as solvents. For example, there are recent reports about the use of dinitrogen oxide (N₂O) as an extracting fluid (Capuzzo *et al.*, 2013). However, the chemical properties of this substance makes N₂O more suited for the extraction of polar compounds with the disadvantage that in the presence of high organic content (e.g., lipids, carbohydrates), the N₂O gas can cause violent explosions among the generation of N-byproducts by *in situ* chemical reactions that strongly limits its use possibilities for conventional algal biomass extraction (Pourmortazavi and Hajimirsadeghi, 2007; Pereira and Meireles, 2010).

Because the extreme physical conditions to carry out critical, subcritical and supercritical fluid extraction it makes necessary the use of same equipment that for

obvious reasons might be constructed in especial materials such as stainless steel that can resist the extreme work parameters.

These technologies therefore, are suffering for its commercial scale and academic research implementation due to concerns associated with, (1) expensive infrastructure, (2) high energy consumption for operation, (3) are appropriate to handled small but not large amount of sample, (4) not suitable for step by step experiments due to the system's decompression for disassemble and (5) the needs of qualified personnel for safety operation (Naghdi *et al.*, 2016).

Therefore, to overcome concerns associate with long time using traditional (Soxhlet) extraction to the expensive for small sample amounts with Supercritical (SCE) technologies, we are introducing a safe, friendly and reliable chemical method described as *semi critical assisted-solvent extraction*, SmCA-Sol, which is an intermediate physical chemistry method where the extracting solvent's temperature and pressure are raised above its standard but far below critical conditions. In this method a binary fluid phase (liquid/vapor) is formed and maintained all the process as result of smoothly changes on one of this two physical variables (temperature or pressure) due to an easy manipulation on some operation parts designed on the extractor's vessel (Fig. 1).

Continuous to step-by-step algal biofuel extraction can be easily carried out under SmCA-Sol conditions on a slightly modified glassware apparatus at isothermal parameters that makes the algal cell wall most exposed for solvent shacking, which is composed by a dynamic binary phase fluid that improves the yield of material released/recovered and characterized for high quality of both organic chemistry composition and physical calorific value.

To that, during the past seven years we have been immersed in the development of thermochemical extraction protocols with the aims of evaluate a variety of agriculture feedstock's that includes wild green algae biomass; especially from wild green *spirogyra. sp* macro algae due to this prokaryotic microorganisms remains a challenge in the algal raw material extraction arena.

An upgraded glassware extractor/separator apparatus (Fig. 1) has been designed to synthesize (at different scales) non-halogenated polar organic azeotropic solvents according with models and principles around empirical rules that apply for more effective and less contaminant solvents for chemical extraction/separation methods. The innovation has been successfully tested on a variety of chemical assisted-solvent extraction and separation protocols that include biodiesel from macro and micro algal origin, within others (Pacheco-Laracuenta *et al.*, 2014).

Herein we are presenting the results obtained on biocrude extraction from wild green *spirogyra. sp* macro algae by comparing Soxhlet (classical syphoning) with a less known Semi Critical Assisted-Solvent method (SmCA-Sol) employing non-chlorinated solvents to evaluate both product yield and biocrude quality.

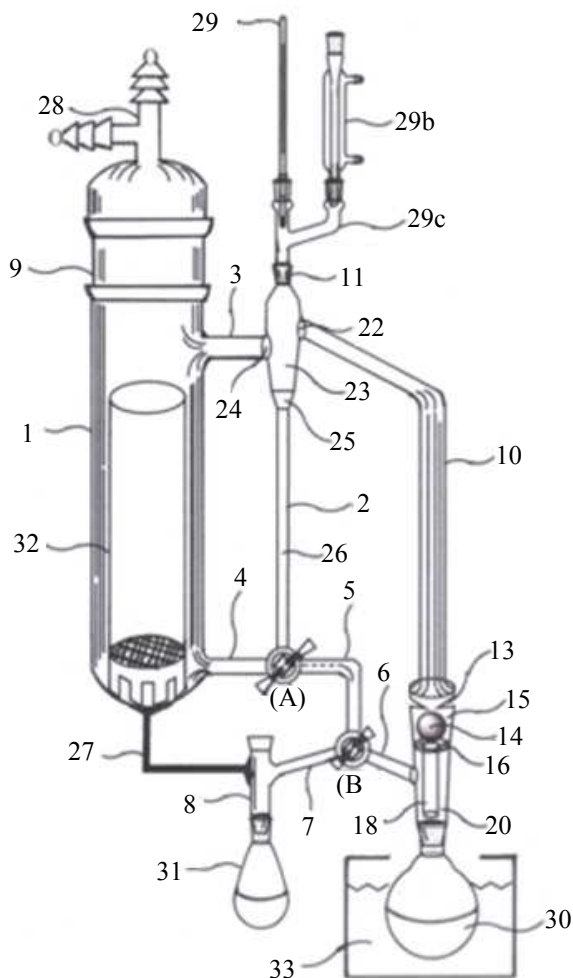

Fig. 1: Glassware design for azeotropes synthesis and semi critical assisted-solvent extraction of hydrocarbons/fatty acid methyl esters from wild green macro algae [scales and illustration's description are given in: Chavez-Gil. T – US-Patent # 9,259,6662. Feb 16, 2016]

The extracting ability achieved under SmCA-Sol conditions can be hypothesized to be associated with an intermediate viscosity composed for a liquid/vapor phase which can be kept constant by the easy manipulation of two valves on the improved extractor for feed either pressure or hot solvent/vapor as desired. With the extractor's thermodynamic improvements, it is thought that large cellular area might be exposed to continuous soaking by hot solvent/vapors increasing percolation frequency in opposite pathways leading therefore, to high yield extraction of hydrocarbon, fatty acids and other valuable materials in a friendly protocol.

Therefore, SmCA-Sol method for algal biocrude extraction enables data acquisition for analysis, help prevents the generation of undesirable byproducts associated with extraction at extreme thermodynamic conditions as occur with supercritical solvents that

deeply modifies biomass chemical composition even under the presence of internal standard co-solvents by adding product separation processes.

Materials and Methods

Azeotropes Synthesis

Pure non-halogenated solvent mixtures were synthesized in the innovated extractor easily and in short time. The physical chemistry analyses of hexane/acetone mixtures were found to be equivalent to that reported in the azeotrope databank (Ponton, 2001), in the hexane/acetone azeotropes (Jalilian, 2007) and on the Dortmund Data Bank Software and Separation Technology GmbH (DDBST, 2015). The azeotrope's boiling points for selected ratios are all at or below the boiling point of pure hexane, therefore no additional energy would be required to perform the proposed extractions. The yields were as high as 80.3% under our conditions for n-hexane-to-acetone (2:1, v/v) with the lowest yield as 57% at 3:1 ratios, respectively. The effects of distillation process, tower height, amount of added solvents ratio, final temperature of head tower to bottom and reflux ratio were investigated.

Algae Preparation

Wild green algae *spirogyra. sp* was harvested in different sampler points during three spring seasons from Guanajibo river (an urban fresh stream head) located in the northwestern region of Puerto Rico Island - US commonwealth territory - with coordinates: N 18°4'12.6516", W 66°59'53.646" with algal growing up under natural conditions. The samples were dried at room temperature for 1-2 days until constant weight was attained. The dried samples were grinded and the obtained low sized particulate was passed through a 500-micron sieve to remove oversized particles and stored for further crude oil extraction.

Soxhlet Extraction

This extraction was performed following published methods (Shafer, 1998) by taking into account the yield of crude oil, experimental time as well as the relation algae mass: Solvent ratio. The thermochemical activity of synthesized azeotropes instead of mix the solvents in the reaction's flask, allows compare chemical effects on cell wall disruption in search to help optimize assisted solvents for thermochemical extraction. To test cell wall activation, six different solvent systems were selected for an initial evaluation, however the azeotrope obtained between hexane/acetone in a 2:1 ratio was finally choice to be the best activant mix for our purposes. Thus, grinded macro algae (~ 10g) was placed into a glassware and base porcelain fritted thimble of internal diameter 25 mm and height of 80 mm and the thimble was placed

inside the extractor's vessel, which is surmounted with a condenser and the vessel suspended above a round bottomed 400 mL flask containing ~250 mL of solvent. The extractions were performed to proceed for 4 h under reflux with subsequent removal of solvent in a rotary evaporator system set at 35°C and 110 mbar. At least 5 replications (each season) for each extraction were performed with the results averaged. The mass of recovered crude oil was compared to the initial dried algal biomass/solvent ratio to determine percent recovery as described in equation 1.

Semi Critical-Assisted Solvent Extraction

The algae biomass extraction under SmCA-Sol parameters was performed on an upgraded apparatus that consists: (1) A compact extractor/separator unit for 450 mL capacity and 55/50 upper port; (2) a two port parallel connected tube possessing a precooling chamber with an upper port design; (3) a spherical design for controlling vapor/steam direction, positioned in the middle portion of a distillation column; and (4) a system composed for two Teflon valves (three ways and 120°C) for liquid/gas upward and downward pathways and pressure control. The main part of the apparatus is a compact extractor/separator design, which is made as glassware Pyrex borosilicate unit with 60 mm internal diameter, 25.0 cm full length and 2.5 mm wall thickness (Chavez-Gil, 2016, US-Patent No. 9, 259. 666).

Thus, grinded macro algae (~ 10g) was placed into a glassware and base porcelain fritted thimble of internal diameter 25 mm and height of 80 mm and the thimble was placed inside the extractor's vessel. On the upper port of the parallel pipe, was installed a glassware Claisen adapter and on it were placed both a thermocouple and a gauge for *in situ*, temperature and pressure measurements, respectively. An automatic, continuous and dynamical extraction can be setup with the compact extractor/separator unit. Hence, a hot vapor/condensate phase percolate through the sample in two opposite pathways at above or below solvent's Standard Temperature and Pressure (STP) conditions. By close the upper port of main condenser with a rubber septum, the extraction system works under semi critical assisted-solvent conditions by crossing the septum with a stainless steel 304 syringe needle, noncoring point gauge 22, length 2" to prevent breakage of the glassware system.

By set up the heating bath (oil or sand) between 50 to 70°C, a vapor pressure of 1.5 to 1.8 atm is achieve for an optimum SmCA-Sol extraction of bio crude from *spirogyra. sp* macro algae with high yields of lipid extracted/recovered in short time (2 h) by employing either plain solvent or azeotrope mixtures. Synthesized azeotropes showed best results in attaining high fractions of crude oil, rather than using the traditional combination of solvents in the reaction flask by assuming the mixture

is composed for pure azeotrope. The extracted oils were recovered by evaporating the solvent in a rotary evaporator system that was set up at 30°C and 100 mbar to remove all solvent.

Results and Discussion

Effects of Semi Critical-Assisted Solvent Extraction on Algae Cell Wall Activation

This study started with the investigation of how the extraction of lipids and hydrocarbons from sources such as wild macro algae can be improved through semi critical-assisted solvent method and the results are presented in Table 1. The results showed that triglycerides and hydrocarbons were effectively extracted in large yields even using pure or azeotropic solvents which production were defined as the mass of product divided by the mass of dry algae feedstock calculated as in Equation 1:

$$\%EOM = \frac{EOM_{total(g)}}{M_{algae(g)}} \times 100 \quad (1)$$

where,

$\%EOM$ = Percentage of extractable oil matter

EOM_{total} = Total oil matter expressed in grams which is the sum of all extracted and identified organic compounds

M_{algae} = The mass of ground algae sample subjected to extraction

Linear solvents (n-alkanes, halogenated hydrocarbons, alcohols) with different chain substituents can form two distinct polar and nonpolar units, which confer the lipophilic character to the molecule and acts as a coactivant on the algae cell wall activation.

The chemical effects of mixed polar azeotropes for algal oil extraction/recovery were earlier demonstrated by using mixtures of n-hexane/alcohol at different ratios (Long and Abdelkader, 2011) on dried *Nannochloropsis* microalgae under Soxhlet traditional method.

Recently, we have reported that not only high yields of algae biocrude can be extracted but also, high percentage of hydrocarbon are recovered utilizing a solvent composed by a polar and non-polar mixture (Chavez-Gil, 2017; Ghasemi *et al.*, 2014).

In this work, was chose as polar activant solvent the n-hexane/acetone azeotrope for wild green macro algae *spirogyra. sp* hydrocarbon and lipids extraction. After several trials at same physical conditions the method shows be dominated for the formation of a homogeneous fluid that greatly enhanced the extraction process and is observed as a single phase (liquid/vapor), which has the characteristic pattern of a laminar flow.

Table 1: Yield of crude oil extracted with pure and solvent mixture [n-Hexane (H), Acetone (A) and azeotrope (H/A)] through soxhlet and semi critical-assisted solvent extraction methods

Algae	Solvent	Extraction method, Yield (wt%) ^{a,b}	
		Soxhlet ^c	SmCA-Sol ^d
<i>Wild green</i>	Hexane	4.91(±0.41)	16.80(±0.52)
<i>Spirogyra sp</i>	Acetone	5.44(±0.26)	18.31(±0.21)
	Azeotrope H/A (2:1)	7.26(±0.45)	34.82(±0.83)

^aStandard deviation, ^b4 h, ^c250 mL, ^d80 mL

Briefly, when a pure solvent or mixture of solvents is heated in a reaction flask, the steam generated creates a lineal or crossed flow inside a conducting cylinder or over an interfering sphere by exhibiting a complex pattern according to thermodynamics.

Liquids and gases share two intensive properties (density, δ and viscosity, ρ) that are directly related to their fluidity and velocity inside a transporting system. However, a gas is more fluid than its original liquid during a mass transport phenomena and thus, its viscosity, which is defined as *the resistance that a part of the fluid shows to the displacement of the other*, controls the process.

Hence, viscosity, ρ is produced by a cutting effect of a layer of fluid when displacing over other and is completely different than the so-called intermolecular attraction. Assuming that a liquid stratifies in molecular planes, a plane's area is defined as A and the inter-planes distance as dy . Also by assuming that each plane in the flow moves to the right with velocities v_1, v_2 , etc., where each value is greater than its predecessor by increment dv .

Therefore, the flow occurring according to this pattern is called *laminar* and is different than the so-called *turbulent* where plane parallelism is not observed (e.g., in supercritical fluid extraction). Thus, in the SmCA-Sol method is hypothesized that it occurs like a laminar flow, with the fluid phase being composed by almost two different physical states (liquid/vapor) but coexisting in equilibrium isothermal. Under this stage of equilibrium the binary fluid possesses the force required to maintain a stationary velocity difference dv between the two parallel planes, which is directly proportional to A and dv and is inversely proportional to dy , according with the relationship:

$$f = \eta A [dv] / dy; f = \eta A [dv / dy] \quad (2)$$

With f = fluid force, η = fluid viscosity coefficient, or simply fluid viscosity and the amount dv/dy in equation (2) refers to the cut velocity, V_c , while the relationship f/A , force per unit of area is called the cutting force, F .

Thus, in terms of V_c and F in Equation (2) it could be transformed into:

$$\eta = F / A \quad (3)$$

In this way, both Equations (2) and (3) could be taken as expressions that define η and the practical application of these properties depends on the validity of a series of experimental assumptions, especially when the flow is laminar [Chavez-Gil, 2016. US-PTO # 9, 259, 666].

In addition to the smoothie laminar patterns that characterize the SmCA-Sol method, the solvents' chemical properties imply a constant soaking track excerpted by different azeotrope fractions on cell matrices. Moreover, by letting fresh wind blow on algal overnight as drying physical pretreatment it facilitates the action of hot polar fraction's to penetrate the water layer micelle on the algae surface to make the lipids inside of it more available for the non-polar solvent fraction in a solvation mechanism (Leite *et al.*, 2013).

Therefore, the yields of biocrude with dried wild green *spirogyra. sp* were significantly enhanced using plain n-hexane from 4.91±0.41% (Soxhlet) to 16.80±0.5% (SmCA-Sol) with extractions carried out under same conditions. Similarly, the use of plain acetone as solvent, gave yields of 5.44±0.26% (Soxhlet) and 18.31±0.21% (SmCA-Sol), suggesting that biocrude extraction/recovery were upgrade (>5 times) under SmCA-Sol conditions rather than with traditional siphoning methods and so similar of yields reported under subcritical or supercritical fluid extraction (Kumar *et al.*, 2015).

Surprisingly, the mixture with best performance for algae biocrude extraction was the n-hexane/acetone (2:1) azeotrope. Multiple trials using this mixture under SmCA-Sol conditions stated that physicochemistry properties in this experimental ratio deeply improves the algal-matrices for solvent interaction by targeting specifically, lipids and hydrocarbons with intermediate chemical composition (C10-C20), which are largely dissolved/recovered.

The advantages assumed for this mixed polar solvent drives to its high lipophilic solvation as prokaryote cell wall disrupter leading to algal protein-lipid matrices to become more soluble in the non-polar solvent fraction (hexane) as mentioned for other polar azeotrope algae extraction reports (Ryckebosch *et al.*, 2014).

The mixture n-hexane/acetone in a 2:1 ratio improves from four to five folds the efficiency on *spirogyra. sp* macro algal biocrude extraction with experiments carried out either in Soxhlet or SmCA-Sol extractors with lipid extraction/recovery ranging from 7.26±0.45% (Soxhlet) to 34.82±0.83% (SmCA-Sol), respectively. Fractionation of biocrude was performed on alumina chromatographic grade 80-200 mesh, with its elemental analysis summarized in Table 1.

Table 2: Elemental analysis, inorganic matter and calorific values of crude oils of *Spirogyra. sp* macro algae

Sample	Element (%) ^{a,b}					Inorganic matter (ppm) ^{c,d}				Calorific value (MJ/kg) ^h	
	C	H	N	O	S ^b	S ^c	Na	K	Ca		V
Crude-oil	72.56	10.59	1.01	15.46	1.10	0.47	46.2	135.2	20.4	105.8	40.55
Residual											8.50
Pure-oil							30.0 ^{d'}	100.0 ^e	20.0 ^{d'}	2000.0 ^f	28.0 ^g

^aGalbraith laboratories, Knoxville, TN., ^bby pyrolysis, ^c[ASTM D-4294], ^dAAAnalyst 100 FLAME Atomic Absorption Spectrometer - [ASTM D-5863 B] method; ^{d'}[ASTM D-7303] method, ^e(Denver *et al.*, 2008), ^f(Vale *et al.*, 2008), ^g(Chaiwong and Kiatsiriroat, 2015), ^hAdiabatic Parr 2901EB Oxygen Bomb Calorimeter [ASTM D-240 Method, 2015]

Interestingly, hydrocarbon and fatty acid methyl ester extracted/recovered showed not only these biofuels being composed by high chemistry quality as profiling by ¹H-NMR (Fig. 4) and GC-MS (Fig. 5) but that they were also recovered in short time (less consumes of energy) whether compared with traditional and close to that achieved with advanced extraction technologies. In addition to hydrocarbon and oil high standards as liquid fuels, the low content of inorganic matter (e.g., S, heavy metals) though about the acceptable to good quality of water whereupon the *spirogyra. sp* under scrutiny acquire its biomass nutrients.

Calorific Value Determination

Total calorific value, H_g , determination were carried out in an adiabatic Parr 2901EB oxygen bomb calorimeter as recommended for the ASTM D-240 method with the average of three experiments summarized in Table 2, than for algae biocrude and also for dried biomass residue. The experiment consists of burn approximately 1.0 g of either column chromatographed biocrude oil or dry algae residue inside a stainless steel reaction chamber under the presence of oxygen, which is pressurized at 20 atm. By follows the method calculations and data analysis the combined results for oil extracted using azeotrope solvent gives calorific values, H_g of 40.55 MJ/kg and same measurements carried out on dried algae residue gives calorific values, H_g of 8.50 MJ/kg, respectively. A minimum of three determinations were carried out for each sample (in different seasons) and a mean is reported.

Elemental analysis was also undertaken for biocrude oil extracted through SmCA-Sol method with chemical composition being dominated by high percent of hydrocarbon (CH) and Oxygen (O) units and advantageously possessing low percentages of nitrogen, sulfur and heavy metals. Surprisingly, the low levels of inorganic matter detected (sulfur and heavy metals) though about the high quality of the urban aquatic biomass on which, the wild green macro algae *spirogyra.*

sp growth up and from where it was harvested during three consecutive seasons.

In addition, the low percentages of N and S detected in the *spirogyra. sp* biocrude are suggesting that this aquatic biomass and its neighboring landscapes are free or less contaminated with hazardous fertilizers and industrial soil pollutants, which are commonly accessed in the biomass that grows in these environment (Sheng and Azevedo, 2004; Lamare and Wing, 2001).

Sulfur (S) content was determinate either as organic matter through pyrolysis (Galbraith laboratories, Knoxville, TN) and as inorganic contaminant by both atomic absorption (AA) spectrometry [ASTM D-5863 B method], as well by Energy-Dispersive X-Ray Fluorescence Spectrometry [ASTM D-4294 method] with those findings summarized in Table 2. The former (AA) method was also used altogether for the analysis of other ions such as Na, K, Ca, and V, which results undoubtedly suggests a direct correlation between these low percentages of inorganic matter in the algae biocrude with its high energy values as determinate in the oils even without a previous esterification.

Fourier Transform Infrared Spectroscopy (FTIR)

The infrared spectrum of crude oil was recorded by using a resolution of 0.09 cm⁻¹ and 32 interferograms on an ABB - FTLA 2000 FTIR spectrophotometer. The spectrum was taken by dropped chromatographed pure sample (neat crude) over KBr window (25 mm diameter × 2 mm thickness) to form a thinnest layer with a circular poly-tetrafluoroethylene (Teflon) spacer hole with thickness of 0.05 - 0.1 mm. The Fig. 2 correspond to IR spectrum that shows a characteristic broad stretch at 3395 cm⁻¹ ascribed to O-H vibration as found in commercial biodiesel (3391 cm⁻¹; Vinita, 2013). A strong mode at 2919 cm⁻¹ is assigned to the asymmetric C-H vibration of CH₂, CH₃ groups of aliphatic chains, whereas the corresponding symmetric stretching for these groups is seen at 2838 cm⁻¹, respectively. A strong stretching at 1701 cm⁻¹ is ascribed at high

content of ester carbonyl groups and carboxylic acids (C=O, COOH) in the crude oils. A moderate stretching at 1274 cm^{-1} , which corresponds to C-O deformation, indicate the ester carbonyl group presence, although other groups also absorb in this region. The presence of carboxylic acid functional group in our extraction was also confirmed by the medium intensity stretch in the region of $1451\text{--}1370\text{ cm}^{-1}$, which can be assigned to the bending of hydroxyl (O-H) group. A weak mode at 1161 cm^{-1} is ascribed to C-O-C

stretching as found in other lipids (Moussa *et al.*, 2014). Two weak absorptions at 1270 cm^{-1} and 822 cm^{-1} are assigned to C-H deformations. The stretching at 1370 cm^{-1} is assigned to C-H/O-H deformation and the stretching with moderate intensity at 951 cm^{-1} is ascribed to -CH_3 rocking. These two low energy stretching taken together demonstrate that both modes have chemical structures identical with those that characterize branched lipids, which have also aromatic/aliphatic rings attached to long hydrocarbon chains.

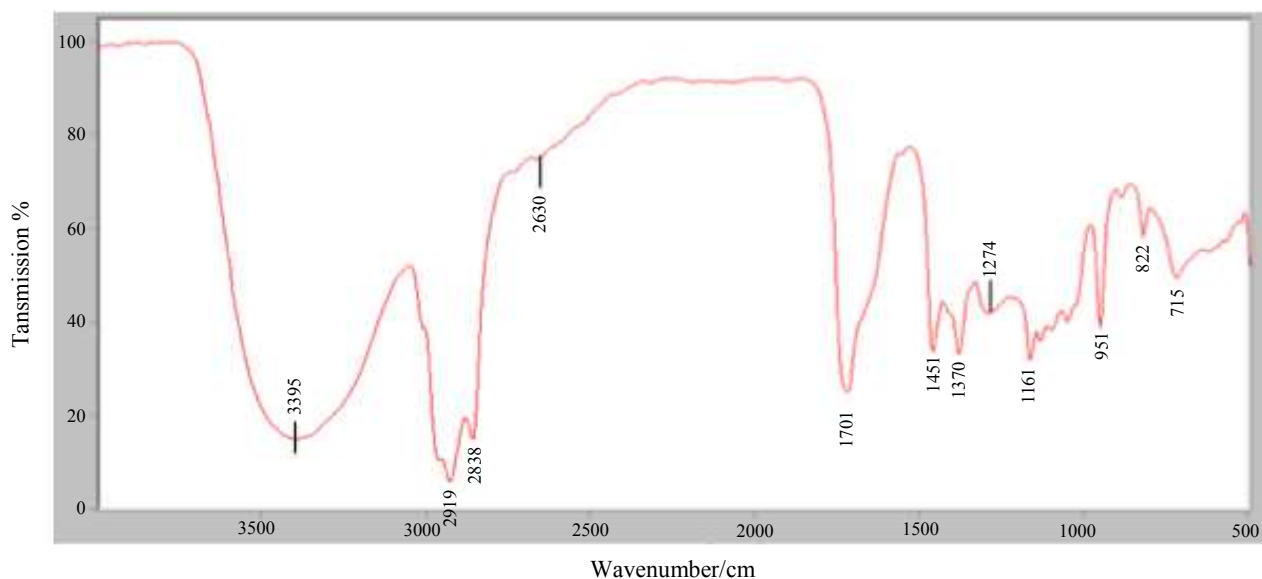

Fig. 2: FT-IR spectrum of net biocrude *spirogyra. sp* macro algal [thin film, 0.1-0.2 mm width] between NaCl 5.0 mm windows

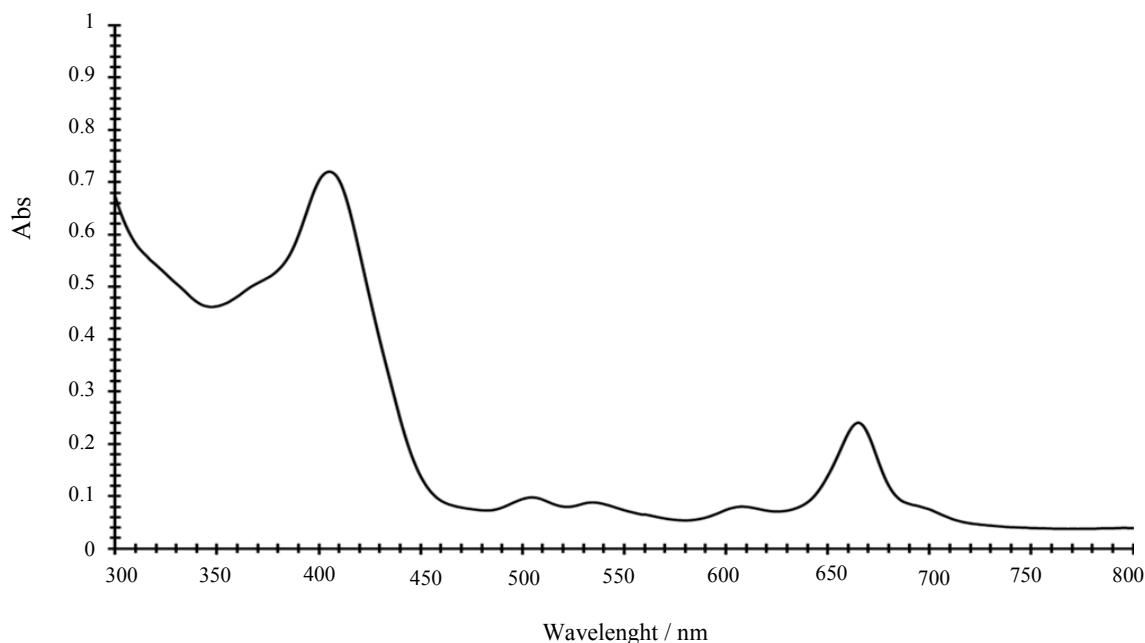

Fig. 3: UV-VIS spectra of net biocrude *spirogyra. sp* macro algae, methanol solution in quartz cuvette 1.0 cm path length

UV-VIS Spectroscopy

Steady-state absorbance spectra were measured on a Perkin Elmer Lambda 850 UV-visible (UV-vis) spectrophotometer and spectra were collected with crude oil dissolved in methanol as depicted in Fig. 3. A strong absorption at 380 nm is ascribed to all sample components with one of those contributing to the characteristic maximum of crude oil absorption in the visible range of spectra. Pure aliphatic acids, esters and corresponding triglycerides are colorless substances and did not exhibit significant absorption in the visible range, but natural fatty acids and oils from plants and animal pigments, commonly exhibits visible absorption as has been found in the *spirogyra. sp* sample (Yoon *et al.*, 2013; Govindarajan *et al.*, 2010).

The presence of metal ions such as vanadium (V^V) and copper (Cu^{II}) enzymes, which are naturally occurring in photosynthetic species can be also detected in the visible

region of spectra below 500 nm (Pacheco-Laracuate, 2015; Kongkiattikajorn and Pongdam, 2006).

Proton NMR Spectroscopy (1H -NMR)

All the 1H -NMR spectra were recorded on a Bruker Avance III 400 MHz NMR spectrometer equipped with dual probe ($^1H/^{13}C$). The solutions were prepared by dissolving approximately 5 to 10 mg of chromatographed crude oil in 0.7 mL of $CDCl_3$ containing internal standard TMS. The instrument parameters such as Relaxation Delay (RD) and Receiver Gain (RG) were optimized and 90° PW calibrated in order to sufficiently relax the nuclei to get the quantitative spectra. The structures of purified crude lipids were confirmed by 1H -NMR (Fig. 4) and the results are summarized in Table 3. The chemical shifts were assigned by comparison with former reported vegetable oils (Shimamoto *et al.*, 2015) and the results were in accordance with structures checked by GC-MS spectrometry.

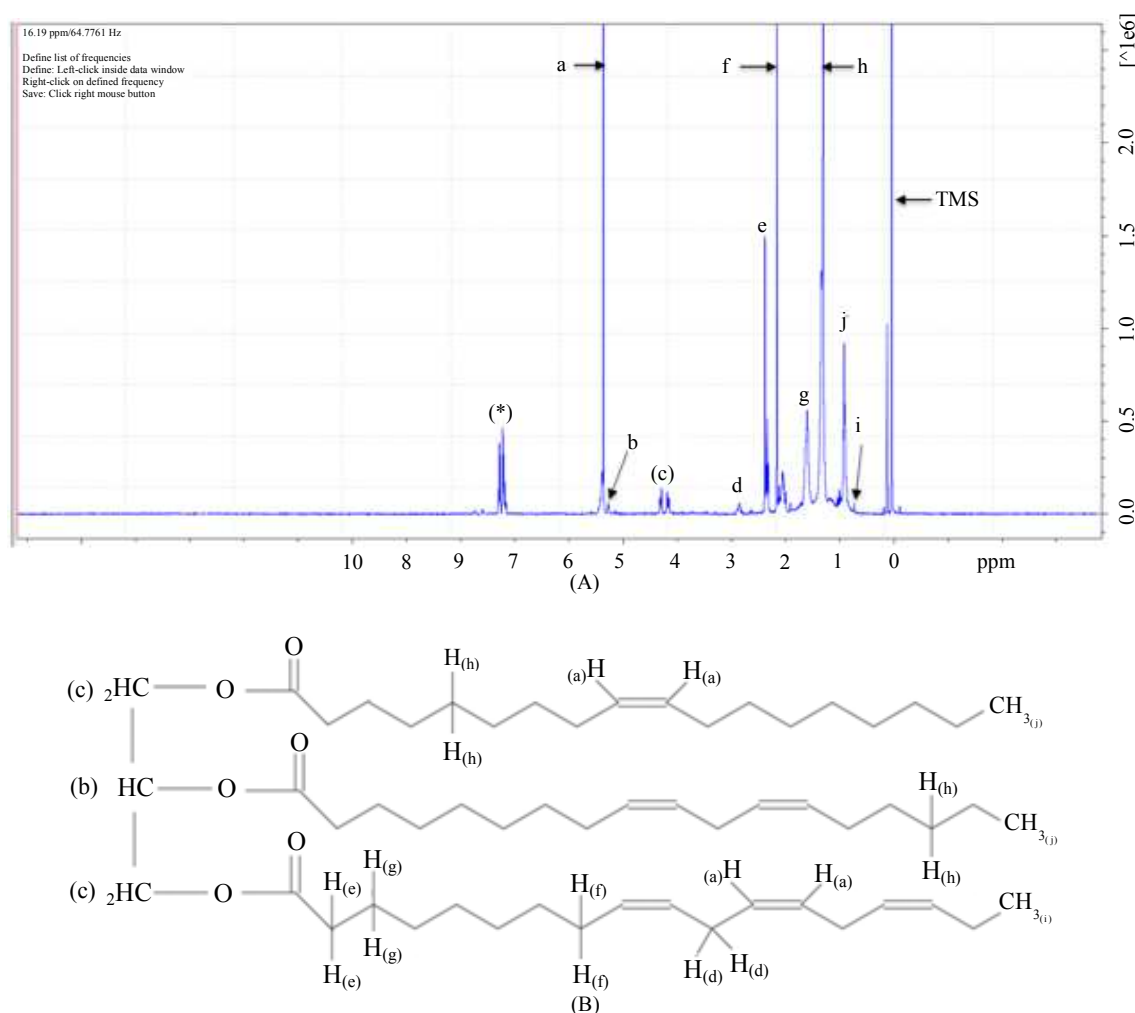

Fig. 4: 400 MHz, 1H -NMR spectra of wild green *spirogyra. sp* crude oil (A) with assignment of hydrogen (by comparison) of an exemplified structure of vegetable oil (B) - Shimamoto *et al.*, 2015 -. (*) = $CDCl_3$

Table 3: ¹H-NMR (400-MHz) chemical shift data for wild green *spirogyra. sp* crude oil

Chemical shift (ppm)	Multiplicity	Assignment (¹ H) (a-j) ^a
0.889	Multiplet	-(CH ₂)-CH ₃ ; (j)
1.085-1.104	Multiplet	-CH=CH-CH ₂ -CH ₃ ; (i)
1.224	Singlet	-(CH ₂) ₃₋₅ -CH ₃ ; (h)
1.581	Multiplet	-(C=O)-CH ₂ -(CH ₂) ₃ - ; (g)
2.021-2.114	Multiplet	-CH ₂ -CH=CH- ; (f)
2.301-2.352	Multiplet	-(C=O)-CH ₂ -(CH ₂) _n - ; (e)
2.851	Multiplet	CH=CH-CH ₂ -CH=CH- ; (d)
4.140-4.180	Quartet	-C-O-CH ₂ -CH- ; (c)
4.270-4.323	Two doublets	-C-O-CH ₂ -CH- ; (c)
5.141-5.155	Multiplet	O-CH ₂ -CH-CH ₂ -O ; (b)
5.261	Singlet	CH ₂ -(CH=CH) _n -CH ₂ ; (a)

^aAs described in Fig. 4b

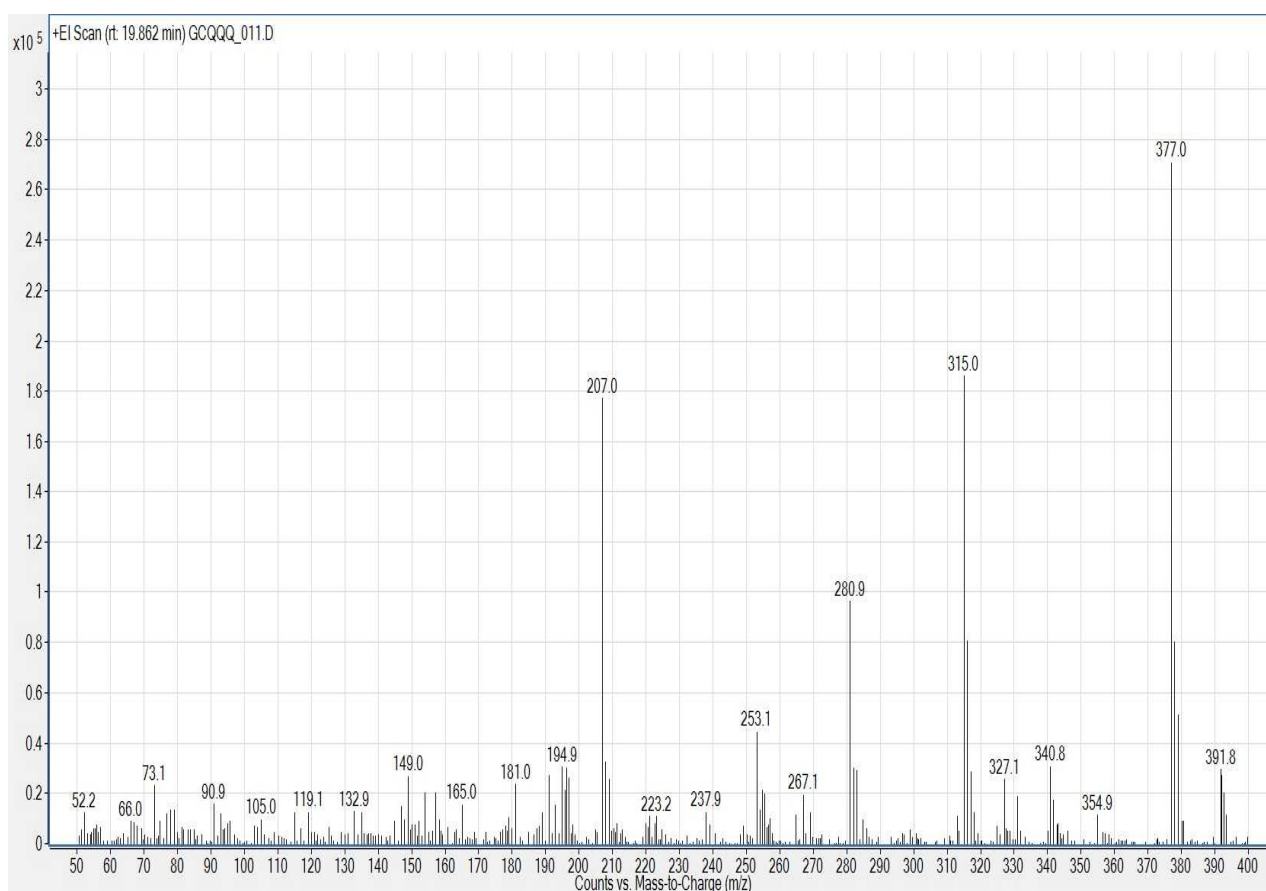

Fig. 5: GC-MS spectrum of *spirogyra. sp* azeotrope fraction with ion pattern for spectral peak at tR 19.86 min

GC-MS Analysis

Gas-Chromatography-Mass Spectrometry (GC-MS) analyses of biocrude extracts were carried out following the method of Hema *et al.* (2010). Thus, all GC-MS measurements of column chromatographed crude oils were carried out on an Agilent 7890 GC system coupled to an Agilent 7000 GC/ MS Triple Quad spectrometer with an Elite-I fused silica capillary column (30m × 0.25 mm ID × 0.25 μm (HP-5 ms). The samples were

prepared by dissolving 1.0 μl of algae biocrude in 10.0 ml of hexane (HPLC grade) with sample vortexed during 5 min and fractions filtered through a 0.2 μm sterile syringe filters. For GC/MS detection, an electron ionization system with ionizing energy of 70 eV was used at scan intervals of 0.5 seconds and fragments from 45 to 450 Da with GC total running time as 30 min.

All samples were used without derivatization and transferred as 200 μl of the prepared solution to the GC-MS sample vials as 5 μl of this solution and injected into

a split/splitter injector with the oven setup at 250°C. The oven temperature was programmed to change from 50°C to 150°C at a rate of 10°C/min (isothermal for 2.5 min) and then from 150 to 270°C at a rate of 5°C/min (isothermal for 30.0 min), ending with an 8.0 min isothermal at 270°C. Helium (He, 99.999% UHP) was used as carrier gas at constant flow rate of 2.0 mL/min and an injection volume of 2 µl was employed at split ratio of (10:1) and injector temperature 245°C; with ion-source isothermal at 270°C. The relative amount (in %) of each chemical component was calculated by comparing its average peak area to the total areas and the software adopted to handle mass spectra data was a Turbomass. The GC/MS analyses were carried out in order to find out hydrocarbons and Fatty Acid Methyl Esters (FAME) present in the crude biofuel of *spirogyra. sp* that shows be a mixture that contain predominant groups of hydrocarbon and lipids as shown in Fig. 5. The structural assignments were based on analysis of fragmentation pattern of mass spectra by direct comparison of this data with profiles in the National Institute of Standards and Technology (NIST2) library and comparisons of mass spectra with data published in the literature.

Five major peaks were detected in the azeotrope fraction at retention times 12.64 min, 19.86 min and 22.00 min (Fig. 5). The GC peak at t_R 19.86 min displayed a molecular ion at m/z 391.8 suggesting a structural formula $C_{27}H_{51}O$. Loss of a methyl ($-CH_3$) from the molecule resulted in m/z 377 mass for a $C_{26}H_{49}O$ fragment. Other characteristic ions include 315 ($M^+ - C_{18}H_{33}O_4^+ - 2H^*$) typical of bis (2-ethylhexyl) ester in addition to peaks at 280 ($M^+ - C_{18}H_{31}O_2$) and 253 ($M^+ - C_{16}H_{30}O_2$) associated with sequentially fragmentation of saturated dicarboxylic acid. Analysis of GC peak at t_R 12.64 min, 19.86 min and 22.00 min revealed a fragment pattern ion at m/z 207 in which $C_{15}H_{28}$ is eliminated, thereby yielding a (2Z, 6Z, 10Z)-3,7,11-trimethyl-2, 6, 10-dodecatrien ($C_{15}H_{27}$) ion. A signal at m/z 166 is typical of an acyclic-type hydrocarbon with formula $C_{12}H_{22}$ ion. A peak at m/z 73 (C_5H_{11}) is an isobutyl ion. Ion peak m/z 52 (C_4H_4) is cyclobutadiene ion. These ions are characteristic of squalene fragmentation. The fragment at m/z 90 ($M^+ - C_4H_9O_2$) corresponds to 2-methyl-propanoic ion. Other intense ions at m/z 194, 184, 149, 207 (base peak, $C_{15}H_{27}$) and 52 are characteristic of saturated and unsaturated alkanes.

Conclusion

Semi critical assisted-solvent method probed be a reliable process to afford for high quality of hydrocarbon and lipid raw material extracted from wild green *spirogyra. sp* macro algae to curve some paramount downstream processing difficulties encountered in the algal biofuel production. In addition to that, non-halogenated polar azeotrope solvents showed best reliability for lipids extraction, as they are tough to provide the highest lipid recovery.

Although new proposed solvent-free methods appear to be promising at laboratory scale, they need more research to be carried out at commercial scale tough to minimize the use of hazard-halogenated solvents.

Our aim in this direction has being the improvement of chemical extraction methods as reliable, less time consume and cost-effective production of high-quality liquid fuels from macro algae within others.

The results presented in this study using both plain and azeotrope mixed polar solvents carried out on a thermochemical upgraded extractor, improved the yield of algal biofuel whether compared with the traditional Soxhlet method. In our investigation was found that plain hydrocarbon solvents are not enough as algae cell wall disrupters whether compared with the effectiveness achieved with synthesized azeotropes possessing mixed polarity.

The reliability of SmCA-Sol extraction shows excellent physical chemistry correlation between hydrocarbon content and calorific values with algal oil analyzed without purification by esterification steps. The high quality of hydrocarbon detected gave a C/H ratio composition for $C_{15}H_{26}$ as main empirical formula in the wild green macro algae *spirogyra* biocrude oil.

Specific components identified by Gas Chromatography-Mass Spectrometry (GC-MS) included unsaturated hydrocarbons and phenols, in addition to heterocycles containing nitrogen as well as long chain fatty acids and amides. In addition to the high percentages of hydrocarbon and oxygen, a low content of nitrogen, sulfur and heavy metals were detected in the macro algae harvested from the urban fresh water stream.

A detailed spectroscopic analysis on biocrude oils was undertaken using FTIR that shows in particular the lipidic components containing oxygen in combination with nitrogen by forming aromatic nitrogen compounds and free fatty acids as predominant chemical structures.

The findings presented are not our concluded work but till addressing a significant improvement on algae cell wall disruption as case study to obtain biofuel with high calorific content very close or beater to those of conventional biomass (9.0-12. MJ/kg).

A continuous work involving semi critical assisted-solvent method using hydrocarbons and polar azeotrope solvents are currently in progress regardless conduct our research to establish an understandable correlation between solvent/algae biomass thermochemical interaction.

Acknowledgement

The authors (T. Ch-G, H.F. Sobhi) are grateful to Coppin State University, Department of Natural Sciences for their administrative support. This work was supported by the University System of Maryland- USM -BOR (Wilson H. Elkins Professorship Award 2016). Special thanks are expressed (In memoriam) to Prof. M^a Y. Perez (Director, Ronald E. McNair program - CFDA No. 84.217A grant - IAUPR-SG) for research financial

support and an undergraduate scholarship (T. Ch-G., A. P-L). The content is exclusively responsibility of the authors and does not necessarily represent the official views of the funding agencies.

Author's Contributions

Tulio Chavez-Gil: Conceived the idea, designed extraction experiments, designed KBr windows for net samples FTIR experiments, constructed the apparatus for semi critical assisted-solvent extraction, coordinate the data-analysis, wrote and edited the manuscript.

Hany F. Sobhi: Performed GC-MS experiments with data analysis-interpretation and help reviewing the manuscript drafting.

Alexis Pacheco-Laracunte: Collected algae samples, performed algae biocrude oils extraction, carried out UV-VIS, FTIR spectroscopic measurements and data analysis, performed bomb calorimeter experiments with data analysis together with elemental and heavy metal analysis.

Ethics

The authors declare no conflicts of interest and states that the research content of this article complies with the ethical standards required by the American Journal of Biochemistry and Biotechnology.

References

- Aitken, D. and B. Antizar-Ladislao, 2012. Achieving a green solution: Limitations and focus points for sustainable algal fuels. *Energies*, 5: 1613-1647. DOI: 10.3390/en5051613
- ASTM D-240 Method, 2015. Standard test method for heat of combustion of liquid hydrocarbon fuels by bomb calorimeter: C1234–D3709.
- ASTM D-4294, 2003. Standard test method for sulfur in petroleum and petroleum products by energy-dispersive x-ray fluorescence spectrometry.
- ASTM D-5863 B Method, 2015. Standard test methods for determination of nickel, vanadium, iron and sodium in crude oils and residual fuels by flame atomic absorption spectrometry.
- Brennan, L. and P. Owende, 2010. Biofuels from microalgae—A review of technologies for production, processing and extractions of biofuels and co-products. *Energy Rev.*, 14: 557-577. DOI: 10.1016/j.rser.2009.10.009
- Capuzzo, A., M.E. Maffei and A. Occhipinti, 2013. Supercritical fluid extraction of plant flavors and fragrances. *Molecules*, 18: 7194-7238. DOI: 10.3390/molecules18067194
- Chaiwong, K. and T. Kiatsiriroat, 2015. Characterizations of bio-oil and bio-char products from algae with slow and fast pyrolysis. *Int. J. Environ. Bioenergy*, 10: 65-76.
- Chavez-Gil, T., 2016. Compact extractor/separator apparatus for solid/liquid/gel sample. United States Patent, US-Patent # 9,259,666-B1.
- Chavez-Gil, T., 2017. Improvements in thermochemical and semi-critical hydrocarbon extraction: Insights into a continuous/fractional fast method for chemicals sample percolation. Proceedings of the 254th ACS-Fall meeting. Aug. 23-23, Washington DC.
- Cheng, M., T. Liu, X. Chen, L. Chen and W. Zhang *et al.*, 2012. Subcritical co-solvents extraction of lipid from wet microalgae pastes of *Nannochloropsis sp.* *Eur. J. Lipid Sci. Technol.*, 114: 205-212.
- Cotton, C.A.R., J.S. Douglass, S.D. Causmaecker, K. Brinkert and T. Cardona *et al.*, 2015. Photosynthetic constraints on Fuel from microbes. *Frontiers Bioeng. Biotechnol.*, 18: 1-5. DOI: 10.3389/fbioe.2015.00036
- DDBST, 2015. Web page and data bank online for free access and solvents/mixture thermochemical calculation. Dortmund Data Bank Software and Separation Technology (DDBST GmbH).
- Denver, J., R. Pyle, A. Garcia and W. Zhiyou, 2008. Producing Docosahexaenoic Acid (DHA)-rich algae from biodiesel-derived crude glycerol: Effects of impurities on DHA production and algal biomass composition. *Agric. Food Chem.* 56: 3933-3939. DOI: 10.1021/jf800602s
- Elliott, D.C., T.R. Hart, A.J. Schmidt, G.G. Neuenschwander and L.J. Rotness *et al.*, 2013. Process development for hydrothermal liquefaction of algae feedstocks in a continuous-flow reactor. *Algal Res.*, 2: 445-454. DOI: 10.1016/j.algal.2013.08.005
- Ghasemi, N.F., S.R. Thomas-Hall, R. Durairatnam, S. Pratt and P.M. Schenk, 2014. Comparative effects of biomass pre-treatments for direct and indirect transesterification to enhance microalgal lipid recovery. *Front Energy Res.*, 2: 1-10. DOI: 10.3389/fenrg.2014.00057
- Govindarajan, L., R. Senthilkumar, N. Raut, H. Bakheet and F.J. Bakheet, 2010. Kinetic study of algae biomass grown in natural medium using spectroscopic analysis. *Algal Biomass Utilizat.*, 2: 1-11.
- Halim, R., B. Gladman, M.K. Danquah and P.A. Webley, 2011. Oil extraction from microalgae for biodiesel production. *Bioresource Technol.*, 102: 178-85. DOI: 10.1016/j.biortech.2010.06.136
- Hema, R., S. Kumaravel, S. Gomathi and C. Sivasubramaniam, 2010. Gas chromatography-mass spectroscopic analysis of lawsonia inermis leaves. *New York Sci. J.*, 3: 141-143.
- Hennenberg, K., U. Fritsche and R. Herrera, 2009. Aquatic biomass: Sustainable bioenergy from algae? *Oko-Institut, Darmstadt, Germany.*

- Hossain, A.B.M.S., A. Salleh, A.N. Boyce, P. Chowdhury and M. Naquiuddin, 2008. Biodiesel fuel production from algae as renewable energy. *Am. J. Biochem. Biotechnol.*, 4: 250-254.
DOI: 10.3844/ajbbsp.2008.250.254
- Huang, H., X. Yuan, G. Zeng, J. Wang and H. Li *et al.*, 2011. Thermochemical liquefaction characteristics of micro algae in sub- and supercritical ethanol. *Fuel Process. Technol.*, 92: 147-153.
DOI: 10.1016/j.fuproc.2010.09.018
- Jalilian, M.R., 2007. Spectra and structure of binary azeotropes: III. Acetone–n-hexane. *Spectrochim. Acta Part A: Molecular Biomolecular Spectroscopy*, 66: 976-978. DOI: 10.1016/j.saa.2006.05.009
- Kapdan, I.K. and F. Kargi, 2006. Bio-hydrogen production from waste materials. *Enzyme Microbiol. Technol.*, 38: 569-582.
DOI: 10.1016/j.enzmictec.2005.09.015
- Kongkiattikajorn, J. and S. Pongdam, 2006. Vanadium haloperoxidase from the red alga *Gracilaria fisheri*. *ScienceAsia*, 32: 25-30.
DOI: 10.2306/scienceasia1513-1874.2006.32(s1).025
- Kumar, R.R., P.H. Rao and M. Arumugam, 2015. Lipid extraction methods from microalgae: A comprehensive review. *Frontiers Energy Res.*, 2: 1-9.
- Lamare, M. and S. Wing, 2001. Calorific content of New Zealand marine macrophytes. *New Zealand J. Marine Freshwater Res.*, 35: 335-341.
DOI: 10.1080/00288330.2001.9517004
- Lee, J.Y., C. Yoo, S.Y. Jun, C.Y. Ahn and H.M. Oh, 2010. Comparison of several methods for effective lipid extraction from microalgae. *Biores. Technol.*, 101: 75-77. DOI: 10.1016/j.biortech.2009.03.058
- Leite, G.B., E.M.A. Ahmed and P.C. Hallenbeck, 2013. Algal biofuels: Challenges and opportunities. *Biores. Technol.*, 145: 134-141.
DOI: 10.1016/j.biortech.2013.02.007
- Long, R.D. and E. Abdelkader, 2011. Mixed-polarity azeotropic solvents for efficient extraction of lipids from *Nannochloropsis* microalgae. *Am. J. Biochem. Biotech.* 7: 70-73. DOI: 10.3844/ajbbsp.2011.70.73
- Metherel, A.H., A.Y. Taha, H. Izadi and K.D. Stark, 2009. The application of ultrasound energy to increase lipid extraction throughput of solid matrix samples (flaxseed). *Prostaglandins Leukot Essent Fatty Acids*, 81: 417-23.
DOI: 10.1016/j.plefa.2009.07.003
- Moussa T.A.A., M.S. Mohamed and N. Samak, 2014. Production and characterization of di-rhamnolipid produced by *Pseudomonas aeruginosa* TMN. *Brazilian J. Chem. Eng.*, 31: 867-880.
DOI: 10.1590/0104-6632.20140314s00002473
- Naghdi, F.G., L.M. González-González, W. Chan and P.M. Schenk, 2016. Progress on lipid extraction from *wet* algal biomass for biodiesel production. *Microb. Biotechnol.*, 9: 718-726.
DOI: 10.1111/1751-7915.12360
- Pacheco-Laracuate, A., 2015. Extraction of crude oil from wild green *Spirogyra* sp: The Effect of polar azeotropic solvents on cell wall activation. MSc Thesis, Inter-American University of Puerto Rico – San German 00683, PR-U.S.A.
- Pacheco-Laracuate, A., S. Villarin-Ayala and T. Chavez-Gil, 2014. High performance of algae-oil extraction: The effect of azeotropic mixtures on cell wall penetration. *Proceedings of the 247th Energy and Fuels ACS Spring Meeting, (ASM' 14)*, Dallas, TX, pp: 594-594.
- Pereira, C.G. and M. Meireles, 2010. Supercritical fluid extraction of bioactive compounds: Fundamentals, applications and economic perspectives. *Food Bioproc. Technol.*, 3: 340-372.
DOI: 10.1007/s11947-009-0263-2
- Perrin, D.D., W.L. Armarego and D.R. Perrin, 1990. *Purification of Laboratory Chemicals*. 2nd Edn., Pergamon, New York.
- Ponton, J., 2001. Azeotrope databank. The Edinburgh Collection of Open Software for Simulation and Education, Edinburgh University.
- Pourmortazavi, S.M. and S.S. Hajimirsadeghi, 2007. Supercritical fluid extraction in plant essential and volatile oil analysis. *J. Chromatogr. A*, 1163: 2-24.
DOI: 10.1016/j.chroma.2007.06.021
- Ramachandra, T.V., D.M. Mahapatra, S. Samantray and N.V. Joshi, 2013. Algal bio fuel from urban wastewater in India: Scope and challenges. *Renewable Sustainable Energy Rev.*, 2: 767-777.
DOI: 10.1016/j.rser.2012.12.029
- Ryckebosch, E., P.C. Bermúdez, R. Termote-Verhalle, C. Bruneel and K. Muylaert *et al.*, 2014. Influence of extraction solvent system on the extractability of lipid components from the biomass of *Nannochloropsis gaditana*. *J. Applied Phycol.*, 26: 1501-1510. DOI: 10.1007/s10811-013-0189-y
- Sahena, F., I.S.M. Zaidul, S. Jinap and A.A. Karim, 2009. Application of supercritical CO₂ in lipid extraction – A review. *J. Food Eng.*, 95: 240-253.
DOI: 10.1016/j.jfoodeng.2009.06.026
- Schafer, K., 1998. Accelerated solvent extraction of lipids for determining the fatty acid composition of biological material. *Anal. Chim. Acta*, 358: 69-77.
DOI: 10.1016/S0003-2670(97)00587-4
- Sheehan, J., T. Dunahay, J. Benemann and P. Roessler, 1998. Look back at the US department of energy's aquatic species program: Biodiesel from algae; Close-Out Report. TP-580-24190, pp: 1-325.
- Sheng, C. and J.L.T. Azevedo, 2005. Estimating the higher heating value of biomass fuels from basic analysis data. *Biomass Bioenergy*, 28: 499-507.
DOI: 10.1016/j.biombioe.2004.11.008
- Shimamoto, G.G., M.M.A. Favaro and M. Tubino, 2015. Simple Methods via Mid-IR or ¹H NMR Spectroscopy for the Determination of the Iodine Value of Vegetable Oils. *J. Braz. Chem. Society*, 26: 1431-1437.

- Soh, L. and J. Zimmerman, 2011. Biodiesel production: the potential of algal lipids extracted with supercritical carbon dioxide. *Green Chem.*, 13: 1422-1429. DOI: 10.1039/c1gc15068e
- Šoštarič, M., D. Klinar, M. Bricelj, J. Golob and M. Berovič *et al.*, 2012. Growth, lipid extraction and thermal degradation of the microalga *Chlorella vulgaris*. *New Biotechnol.*, 29: 325-331. DOI: 10.1016/j.nbt.2011.12.002
- Sotoft, L.F., B. Rong, K.V. Christensen and B. Norrdahl, 2010. Process simulation and economical evaluation of enzymatic biodiesel production plant. *Biores. Technol.*, 101: 5266-5274.
- Turkenburg, W.C., 2000. Renewable Energy Technologies. In: *World Energy Assessment*, Preface, Goldemberg, J. (Ed.), United Nations Development Program, New York, USA, pp: 219-272.
- Vale, M.G.R., M.M. Silva, I.C.F. Damim, P.J.S. Filho and B. Welz, 2008. Determination of volatile and non-volatile nickel and vanadium compounds in crude oil using electrothermal atomic absorption spectrometry after oil fraction into saturates, aromatics, resins and asphaltenes. *Talanta*, 74: 1385-1391. DOI: 10.1016/j.talanta.2007.09.009
- Vinita, E.M., 2013. Isolation, characterization of algae and production of biodiesel. *Int. J. Res. Revi. Pharm. Applied Sci.*, 3: 321-330.
- Yoon, M., J. Choi, G.H. Kim, D.H. Kim and D.H. Park, 2013. Proteomic analysis of *spirogyra varians* mutant with high starch content and growth rate induced by gamma irradiation. *Bioprocess Biosyst. Eng.*, DOI: 10.1007/s00449-013-0902-x